



MODULE LAUNCH

CRMT120 STUDIOCRAFT

CRMT120 STUDIOCRAFT
DR ANTTI SAKARI SAARIO
SB1, WEEK 1 SEMINAR
20 SEPTEMBER 2022

FALMOUTH
UNIVERSITY

 Academy of Music
& Theatre Arts

KEY MODULE INFORMATION

CODE: CRMT120

MODULE: STUDIOCRAFT

CREDITS: 20

MODULE LEADER: Dr Antti Sakari Saario

OTHER MODULE STAFF:

- > Keith Michael (Drum Tutor)
- > Alex Smith (Technician: Sound)
- > Robin Tyndale-Biscoe (Associate Lecturer)

ASSESSMENT: PRACTICAL STUDIO ASSESSMENT (30%) + PORTFOLIO (70%) (see MyFalmouth for your hand-in deadline)

MODULE AIMS

1. To develop **technical skills** in sound recording applicable to a wide range of instrumental sound sources and musical genres.
2. To inculcate **professional studio etiquette**, work ethic, session management and interpersonal skills that nurture strong musical performances
3. To develop both a **critical and experiential understanding** of the relationship between recording technology and musical practice.

SKILLS DEVELOPMENT

Skills development for your future is at the core of the CRMT120 module and you are expected to be working towards improving your skills in the below categories.

KNOWLEDGE & UNDERSTANDING: This module develops knowledge and understanding in the theory and practice of sound recording.

INTELLECTUAL SKILLS: You will be helped to critically analyse personal, peer and industry practice. Class discussions and learning tasks will aid with the development of an understanding of the role of sound recording in music and wider culture.

PRACTICAL SKILLS: This module introduces students to the craft of sound recording, focusing on optimising instrumental sound and performance practice, understanding microphone technique and its interaction with acoustics, analogue signal flow and the use of analogue mixing desks and Digital Audio Workstations.

TRANSFERABLE SKILLS: Successful completion of tasks will require excellent interpersonal skills, good time management, IT skills, research methods and the ability to critically evaluate work.

SUMMARY MODULE

DESCRIPTION

Studiocraft is about effective **working with instruments, spaces, equipment and people**, in the context of contemporary studio-based music recording and production.

Studiocraft introduces students to the **art and craft of sound recording** and focuses on both the technical and personal skills necessary for achieving high-quality recordings.

These two themes are explored in parallel with students learning the **psychology and diplomacy** of getting the best performances from musicians, while also gaining a **comprehensive introduction** to the techniques of studio recording.

The module follows the **journey of sound** from source to recording media, and covers themes including acoustics, instrument optimisation, microphone technique and analogue and digital signal flow, as well as a variety of recording technologies.

Students will be introduced to **industry-standard production techniques and workflows**, which will be continuously measured against detailed **critical listening**. Critical listening materials will be integrated into the teaching, offering exemplars of techniques discussed.

Portfolio development will be supported by tutorials with staff, in addition to seminars and specialist lectures, learning materials and guided learning tasks.

Discussion around the key themes and technologies introduced will always be rooted in a **critical context**.

You will be actively encouraged to **think creatively** about the variety of possible modes of engagement and the associated material affordances and constraints you might have with studio technologies.

The module also places a strong emphasis on **session planning and management, people skills, professional studio etiquette and work ethic**, as associated with contemporary studio production.

WHAT DO WE DO IN STUDIOCRAFT?

MODULE OVERVIEW//TIMELINE

CRMT120 MASTER MAPPER 2022-23

	1	2	3	4	5	6	7	8	9	10	11	12	13	14	15
WORKSHOP	VOCALS	MONO MIC	MULTI-MIC / PHASE / REAMP	STEREO PIANO				TRACKING GROUPS 1-2	TRACKING GROUPS 3-4	TRACKING GROUPS 1-2	TRACKING GROUPS 3-4				
PRACTICAL	MIC TEST SIGNAL FLOW	ACOUSTIC SOURCE	OVERDUB / DI	ACOUSTIC GUITAR									STUDIO TUTORIALS		
KEY TOPICS	CRITICAL LISTENING, SIGNAL FLOW	MICROPHONES CHARACTERISTICS	DI, REAMP, PHASE	STEREO BASICS	DRUM RECORDING, MONITOR MIXES	ADVANCED DRUM RECORDING		MIX BASICS	SESSION TIPS	ACOUSTICS PRIMER	ADVANCED SIGNAL FLOW	STUDIO REPORTS			
SEMINAR // STUDIO REVIEW	MODULE LAUNCH				ASSESSMENT PREPARATIONS		TRACKING SESSION PLANNING		ASSESSMENT FEEDBACK & REFLECTION	ACOUSTICS IN RECORDING		TRACKING REVIEW			FINAL REVIEW
STUDIO TASK								SETUP + MIX	SETUP + MIX	SETUP + MIX	SETUP + MIX	MIX CHECK			
SYNC SESSION	REFLECTIVE TOUCHPOINT	REFLECTIVE TOUCHPOINT	REFLECTIVE TOUCHPOINT	REFLECTIVE TOUCHPOINT				REFLECTIVE TOUCHPOINT	REFLECTIVE TOUCHPOINT	REFLECTIVE TOUCHPOINT	REFLECTIVE TOUCHPOINT				
ASSESSMENT							STUDIO ASSESSMENT								SUBMIT PORTFOLIO

INTRODUCTION TO ASSESSMENT BRIEFS

PRACTICAL STUDIO ASSESSMENT (30%)

Submission element: Practical Studio (in-class) assessment

Assessment Weighting: This assessment task contributes 30% towards your overall module mark.

Deadline: See your MyFalmouth.ac.uk for your submission deadline details. Default deadline is in Study Block 1 Week 7 class.

Overview: You are to carry out a multi-track recording of an acoustic drum kit during a timetabled 2.0 hr studio session in Week 7. The task assesses effective studio and group working skills in a recording scenario involving: (1) a complex acoustic sound source; (2) multiple microphones; and (3) single recording space. You are expected to demonstrate basic microphone and recording techniques, understanding and application associated theories, in a professional studio context. The session will test your session planning skills, practical real-time problem-solving ability, as well your ability to work effectively both independently and as part of a team. You are expected to evidence *in situ* critical engagement with, and evaluation of, the given studio tasks, recorded sound quality and skills development.

The tasks effectively draws from and builds on the techniques and principles covered in Weeks 1-6 lectures, seminars, workshops, practical sessions, learning tasks and associated learning materials (e.g. setting up headphone monitoring mixes, gain staging of microphones, setting up, testing and comparing microphones, practical application of mono, multi-microphone and/or stereo recording techniques, management of phase relationships) and Week 5 Seminar will be focused around preparing, planning and managing a studio session.

PORTFOLIO (70%)

The PORTFOLIO submission comprises STUDIO PRODUCTION materials and CRITICAL DOCUMENTATION.

Weighting: This coursework PORTFOLIO task contributes 70% towards your overall module mark.

Task: Your task is to carry out a complete multitrack studio production of a single piece of music, from conception to a 24bit 48kHz stereo mixdown and to write a critical documentation of the production, using the Week 7-11 in-class POPM tracking sessions as the basis for your production.

The PORTFOLIO submission upload must include:

1. Your unmastered **final mix** of your STUDIO PRODUCTION as 24bit/48kHz interleaved stereo .WAV file
2. **Completed copy** of the WRITTEN DOCUMENTATION
3. **Screenshots** of your DAW mix session showing signal flow and processing chains
4. **Edited examples** of all your original unprocessed recordings that the finished track comprises as 24bit/48kHz .WAV files whereby mono sources are provided as mono audio files and stereo sources as interleaved stereo files.

NOTE THE FOLLOWING for the PORTFOLIO SUBMISSION:

- > The final mixes must be in two-channel stereo and submitted as 24bit, 48kHz, .WAV files
- > There are no genre or stylistic limitations to the final production but the submitted production must demonstrate musical awareness of and sensitivity to the 'track' in question
- > The production must make prominent use of microphone recordings of acoustic and/or electro-acoustic sound sources
- > You must state explicitly your intended production aims, strategies and subsequent production processes
- > You are free to use any available hardware and software to carry out the task
- > You can download the CRITICAL DOCUMENTATION template from the CRMT120 Learning Space (under 'Assessment')
- > The tracking sessions are carried out in timetabled Groups session and you can further collaborate with your CRMT120 peers in your final submission (e.g. to make a collective mix, add new parts). In the case of a group mix submission, each group member must report an individual CRITICAL DOCUMENTATION.
- > The word count for each section of the CRITICAL DOCUMENTATION is shown on the form. Harvard referencing should be used with full references provided. Please note that the references do not count towards the REPORT word count.
- > In exceptional cases, a different recording than that of the POPM tracking sessions can be used as the basis for the production, subject to Module Leaders prior approval.

ASSESSMENT: MODULE LEARNING OUTCOMES (LO)

The CRMT120 Studiocraft Module has two distinct assessment elements which are used to assess your achievement against the Module Learning Outcomes (LOs). Please see the below table for which LOs are being assessed by each CRMT120 assessment element.

ASSESSMENT ELEMENT	ASSESSMENT WEIGHTING	LEARNING OUTCOMES ASSESSED					COMPULSORY or COMPENSATABLE
		CREATIVITY	CRITICAL THINKING	PROFESSIONALISM	RESEARCH	SKILLS	
PRACTICAL	30%		Y	Y		Y	COMPENSATABLE
PORTFOLIO	70%	Y	Y	Y	Y	Y	COMPENSATABLE

The tables on following slides shows the CRMT120 LOs and their associated Assessment Criteria. Do note that you submissions can only be assessed against the Module LOs.

CRMT120 Learning Outcomes STUDIO PRACTICAL (30%)	ASSESSMENT CRITERIA To achieve the Learning Outcome you must demonstrate the ability to:	FURTHER DETAIL
CRITICAL THINKING Think critically about concepts, contexts and practice, evaluating these through scholarship and/or self-reflection.	Demonstrate through practical work, a clear rationale for the artistic and technical decisions you have made in the development of your recording project. Evidence of critical listening and critical awareness and understanding of relationship between technologies, concepts, contexts and practices associated with studio recording.	<ul style="list-style-type: none"> > Reasoning behind production actions during the session > Evidence of critical listening during the studio session > Ability to trouble shoot and solve set challenges and emergent problems
PROFESSIONALISM Demonstrate the application of industry standards and recognised external arbiters of best practice within your discipline, including appropriate project management.	Demonstrate through practical work, an awareness of best practice, as benchmarked against industry standards, in the technical, artistic and interpersonal skills needed to bring about your recording project.	<ul style="list-style-type: none"> > Communication during session and ability to work independently and as part of a team > Time, task, session and file organisation and management > Efficiency of workflow and clarity of recording setup > Knowledge of relevant industry standard recording techniques > Standard of audio quality
SKILLS Demonstrate a sufficiently high-quality skill set to realise your work.	Demonstrate through practical work, competency in a range of studio recording and production techniques.	<ul style="list-style-type: none"> > Safe, appropriate and effective handling of recording equipment and software > Effective signal routing > Effective application of microphone and recording techniques in the given tasks

CRMT120 Learning Outcomes PORTFOLIO (70%)	ASSESSMENT CRITERIA To achieve the Learning Outcome you must demonstrate the ability to:	FURTHER DETAIL
CREATIVITY Demonstrate a creative and innovative approach to ideas, materials, and methods.	Demonstrate through practice, your creative approach to sound recording to support the aesthetic aims of a piece of music. Demonstrate creative application of recording techniques, technologies and production processes in a contemporary studio production context.	> Musically sensitive and contextually appropriate application of creative production techniques and
CRITICAL THINKING Think critically about concepts, contexts and practice, evaluating these through scholarship and/or self-reflection.	Demonstrate through practical and written submissions, a clear rationale for the artistic and technical decisions you have made in the development of your recording project. Evidence of critical listening and critical awareness and understanding of relationship between technologies, concepts, contexts and practices associated with studio recording.	> Rationale for artistic and technical decisions > Project evaluation (documentation)
PROFESSIONALISM Demonstrate the application of industry standards and recognised external arbiters of best practice within your discipline, including appropriate project management.	Demonstrate through practical and written submissions, an awareness of best practice, as benchmarked against industry standards, in the technical, artistic and interpersonal skills needed to bring about your recording project.	> Sound quality and adherence to professional production standards. > Overall project management and the quality and consistency of engagement with all production stages (pre-production, recording, mixing) > Presentation of submission materials
RESEARCH Produce informed work through the use of appropriate research methods.	Demonstrate through documentation, the technical and artistic research undertaken in the development your recording project.	> Use of multiple and varied relevant sources to inform your production > Correct use of Harvard referencing for all sources
SKILLS Demonstrate a sufficiently high-quality skill set to realise your work.	Demonstrate through practical work, competency in a range of studio recording and production techniques.	> Application of microphone and recording techniques > Competency of editing, mixing and audio processing

INTRODUCING

W1 STUDIO PRACTICAL

INTRODUCING

W1 STUDIO WORKSHOP

SIGNAL FLOW

OVERVIEW



DIGITAL
SIGNAL

ANALOGUE
SIGNAL

PHYSICAL
SOUND

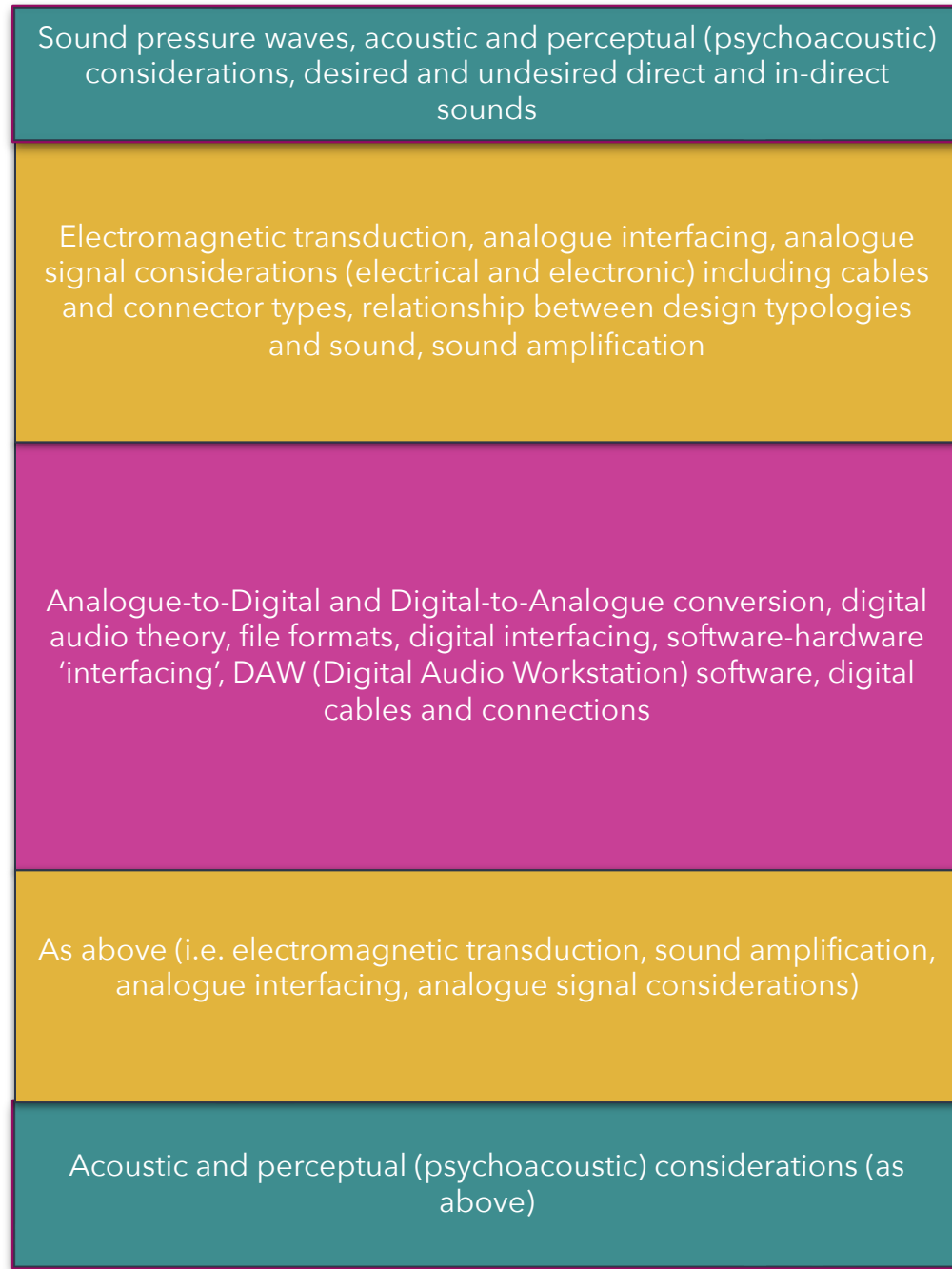
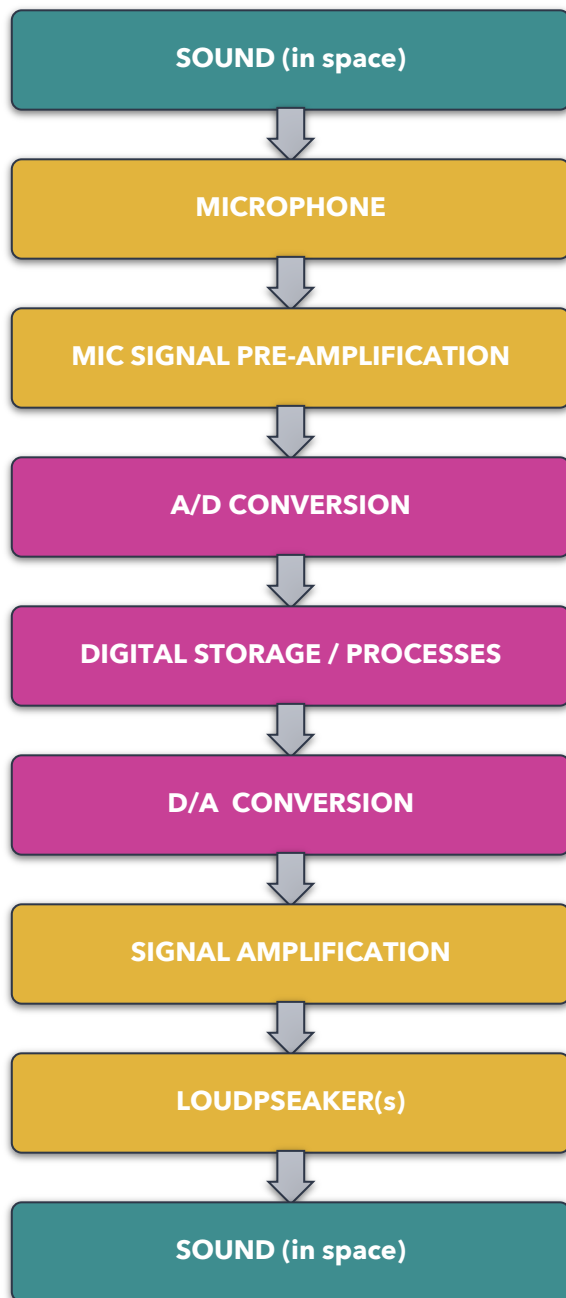

MAKING CONNECTIONS

- > In simple terms, we are connecting OUTPUTs of a devices to INPUTS of the next device in the signal chain
- > Input and output level matching and/or balancing in terms of signal level and impedance
- > Connector types
- > Always troubleshoot any issues with your signal flow by starting at one end of the signal chain, checking each stage' at a time (i.e. do not start from the 'middle' of the chain)
- > Note the terminology used in the AMATA patchbays with regards to the various studio spaces
- > Note the potential for 'reversing' signal flow (e.g. SENDs and RETURNS on a stage- or wall-box)
- > Patchbays, wall- and stage-boxes

BASIC INPUT ('REC') SIGNAL TYPES

MICROPHONE LEVEL SIGNALS in professional studio context are (nearly always):

> Low level, **balanced**, micro-millivolts, low impedance (<600 ohms)

Thus, we will need to amplify mic level signals to **line level** signals in order to interface the signal with (most) processing devices and A/D converters. This in turn necessitates considerations for setting levels between devices ('gain staging') and impedance matching (primarily for 'colour')

LINE LEVEL SIGNAL are either:

A. balanced, > 1V, low impedance (approx. 10 ohms) (+4dBu)

B. unbalanced, do not benefit from Common Mode Rejection (-10 dBu)

INSTRUMENT LEVEL SIGNAL (Hi-Z = high impedance) are:

> **unbalanced**, low level, and high impedance (up to 1M ohms)

In order to interface instrument signals with the recording chain, we will need to convert these signals to balanced, low impedance, low level (mic level) signals using a DI (Direct Injection) box. We are having to consider impedance and level matching.

VIDEO EXAMPLE: INPUT SIGNAL TYPES

- > WATCH the short [2'56"] video 'Understanding Input Signal Path' by CRANE, Larry (2013)

Accessible from LinkedIn Learning using your Falmouth log-in credentials:

<https://tinyurl.com/kj3h3rfu>

VIDEO EXAMPLE: FEW NOTES ON GAIN STAGING

> WATCH the short [2'03"] video 'Gain Staging' by CRANE, Larry (2013)

Accessible from LinkedIn Learning using your Falmouth log-in credentials:

<https://tinyurl.com/4zsrwkv3>

AMATA

SIGNAL FLOW

AMATA Signal Flow Map

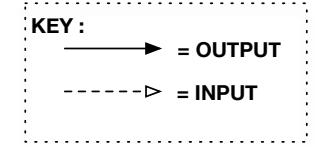
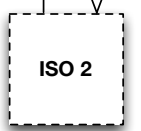
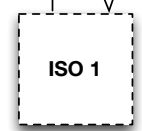
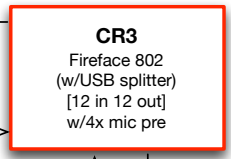
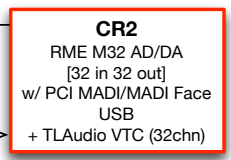
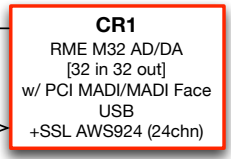
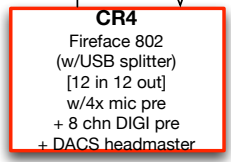
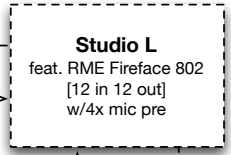
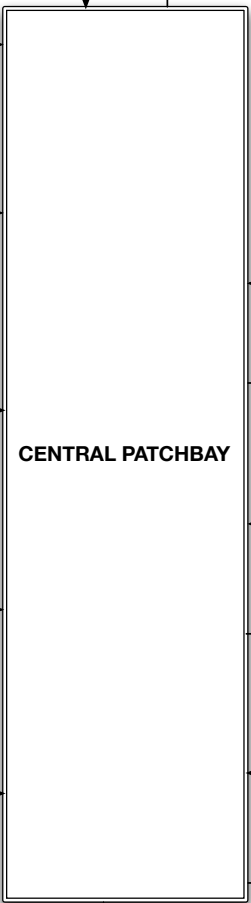
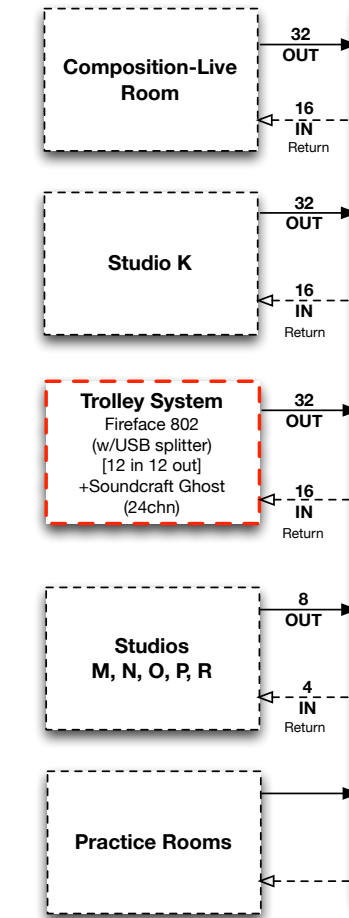
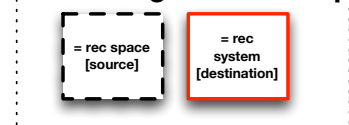

CONTROL ROOM 1
SIGNAL PATH
EXAMPLES

BASIC SIGNAL PATH: DAW **RECORD** (COMP/LIVE > CR1)

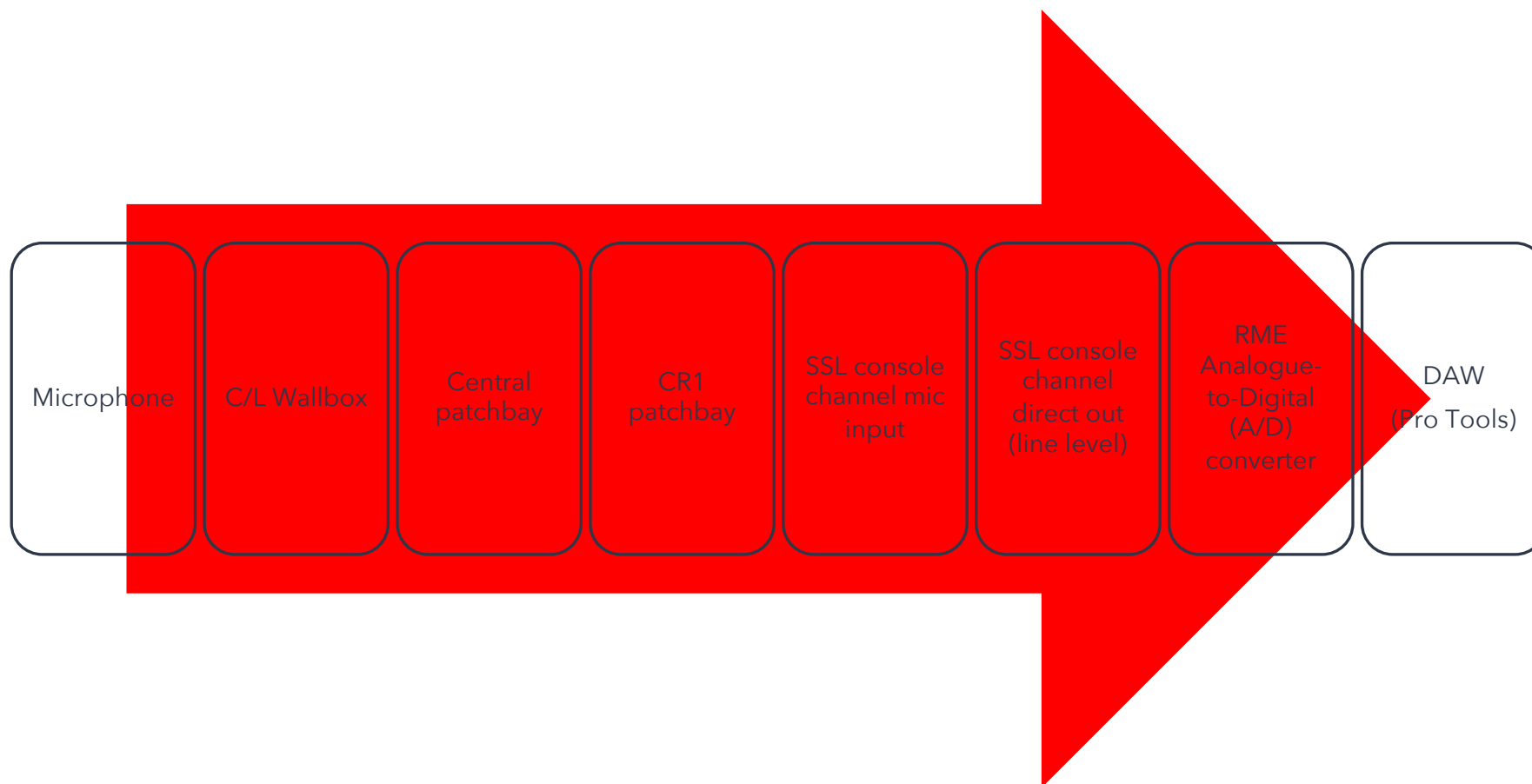

BASIC SIGNAL PATH: DAW **PLAYBACK** (CR1)

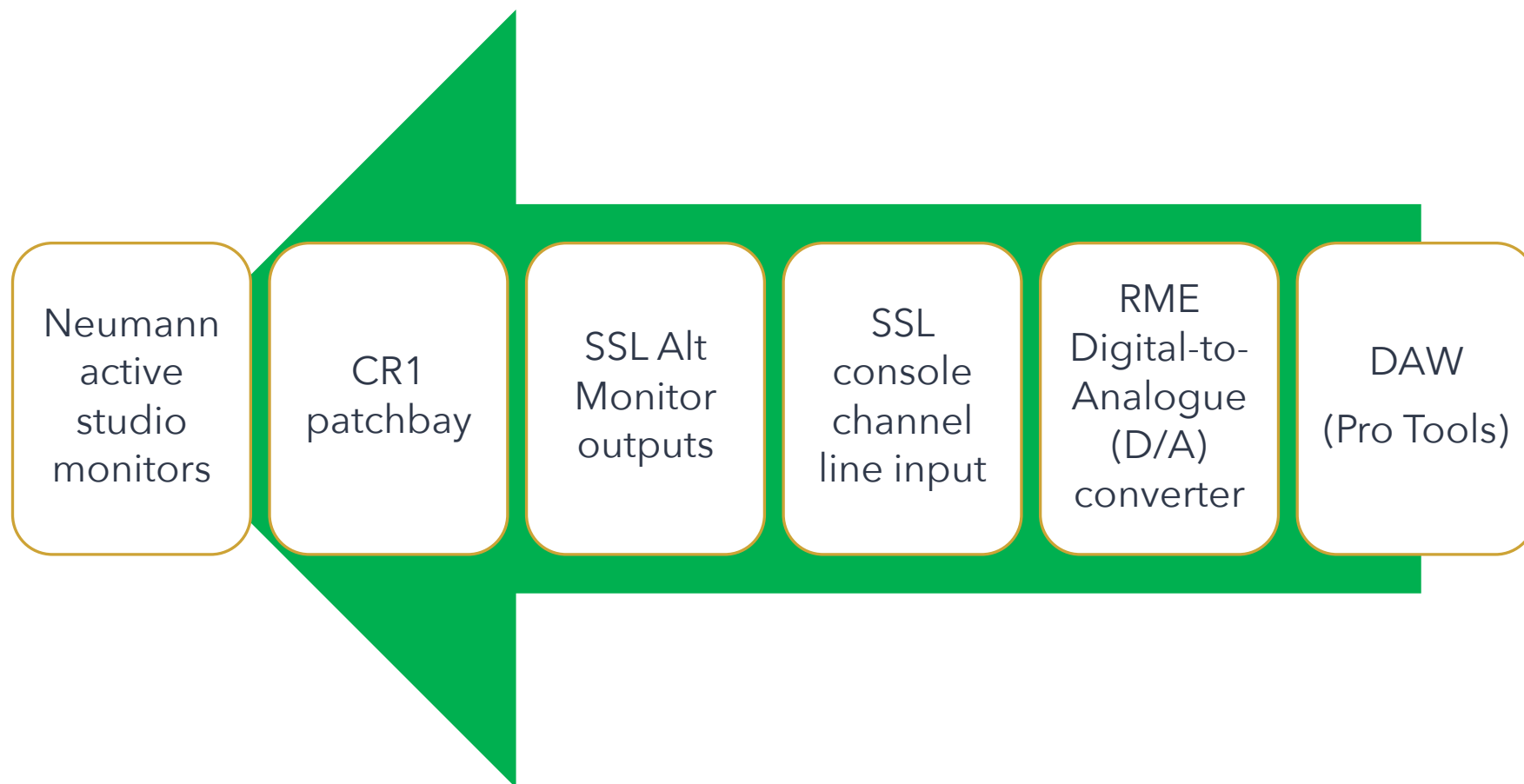

PATCHBAY CONNECTION TYPES

VIDEO EXAMPLES AND FURTHER READING

WATCH the three short video tutorials by Bittree Patchbays on the basic patchbay connection types (see CRMT120 Learning Space for links)

> [Non-Normal Patchbay Setup](#) (aka Open connection) [Dur: 0'43"]

> [Half-Normal Patchbay Setup](#) (aka Half-normalled connection) [Dur: 1'04"]

> [Full-Normal Patchbay Setup](#) (aka Normalled connection) [Dur: 0'54"]

READ the short Sound on Sound article patchbays ROBJOHNS, Hugh. 2020.

Patchbays In The Modern Studio. How To Choose The Right One For You. Sound On

Sound. <https://www.soundonsound.com/techniques/patchbays-modern-studio>

BACK of unit

TO and FROM

EQUIPMENT inputs/outputs

(e.g. mic pre, compressor, AD/DA)

FRONT of unit

GPO (B)

CONNECTIONS

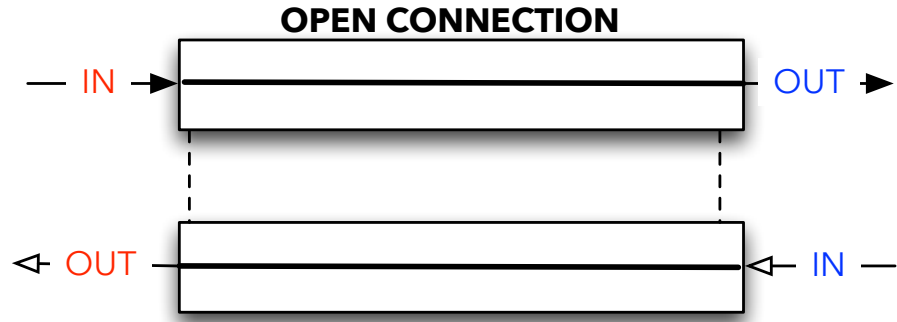

No default internal connection - the signal must be 'patched in' using GPO cables.

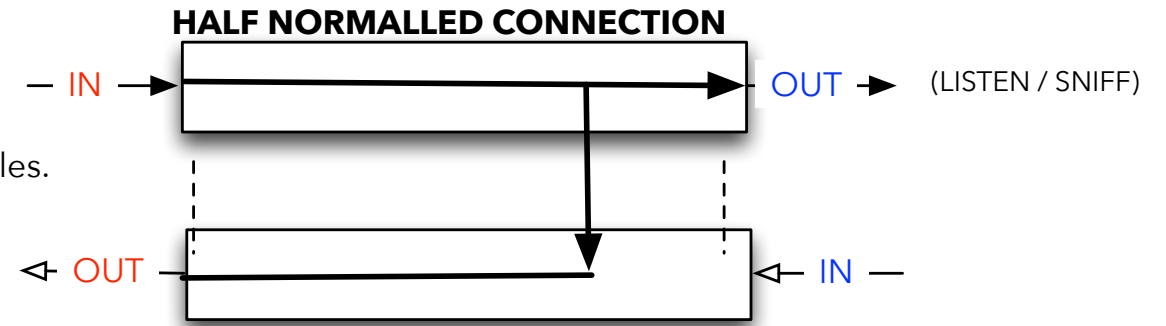

Internal connection gets broken ONLY if a cable is connected to BOTTOM socket. (i.e. Signal can be sent to 2 destinations unless we break the internal connection)

[e.g. an insert point in the TLAudio VTC console]

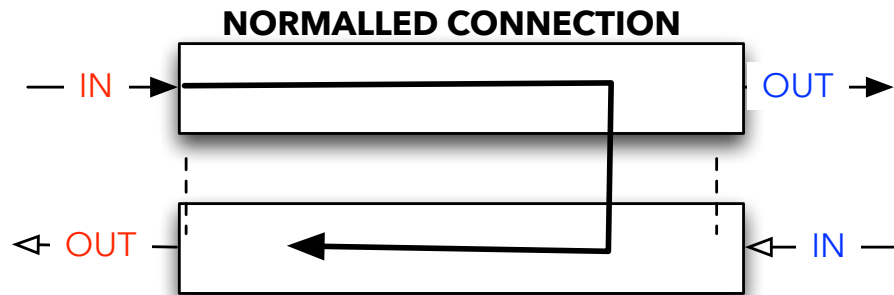

Internal connection gets broken if a cable is connected to either TOP or BOTTOM socket.

[e.g. Microphone tielines from CENTRAL PATCHBAY to CR1 SSL mic inputs (=mic preamplifier input)]



AMATA PATCHBAYS

Recording Hall 2 Patch Bay - Audio

A	1	2	3	CONTROL 1 INPUTS				6	7	8	9	10	11	CONTROL 1 INPUTS				16	1	2	3	CONTROL 1 OUTPUTS				8	A
	ANALOG	1	2	3	4	5	6	7	8	9	10	11	12	13	14	15	16	17	18	19	20	21	22	23	24	ANALOG	
B	17	18	19	CONTROL 1 INPUTS				22	23	24	25	26	27	CONTROL 1 INPUTS				32	9	10	11	CONTROL 1 OUTPUTS				16	B
	ANALOG	17	18	19	20	21	22	23	24	25	26	27	28	29	30	31	32	9	10	11	12	13	14	15	16	ANALOG	

C	1	2	3	CONTROL 2 INPUTS				6	7	8	9	10	11	CONTROL 2 INPUTS				16	1	2	3	CONTROL 2 OUTPUTS				8	C
	ANALOG	1	2	3	4	5	6	7	8	9	10	11	12	13	14	15	16	17	18	19	20	21	22	23	24	ANALOG	
D	17	18	19	CONTROL 2 INPUTS				22	23	24	25	26	27	CONTROL 2 INPUTS				32	9	10	11	CONTROL 2 OUTPUTS				16	D
	ANALOG	17	18	19	20	21	22	23	24	25	26	27	28	29	30	31	32	9	10	11	12	13	14	15	16	ANALOG	

E	1	2	3	CONTROL 3 INPUTS				6	7	8	9	10	11	CONTROL 3 INPUTS				16	1	2	3	CONTROL 3 OUTPUTS				8	E
	ANALOG	1	2	3	4	5	6	7	8	9	10	11	12	13	14	15	16	17	18	19	20	21	22	23	24	ANALOG	
F	17	18	19	CONTROL 3 INPUTS				22	23	24	25	26	27	CONTROL 3 INPUTS				32	9	10	11	CONTROL 3 OUTPUTS				16	F
	ANALOG	17	18	19	20	21	22	23	24	25	26	27	28	29	30	31	32	9	10	11	12	13	14	15	16	ANALOG	

J	1	2	3	TROLLEY INPUTS				6	7	8	9	10	11	TROLLEY INPUTS				16	1	2	3	TROLLEY OUTPUTS				8	J
	ANALOG	1	2	3	4	5	6	7	8	9	10	11	12	13	14	15	16	17	18	19	20	21	22	23	24	ANALOG	
K	17	18	19	TROLLEY INPUTS				22	23	24	25	26	27	TROLLEY INPUTS				32	9	10	11	TROLLEY OUTPUTS				16	K
	ANALOG	17	18	19	20	21	22	23	24	25	26	27	28	29	30	31	32	9	10	11	12	13	14	15	16	ANALOG	

G	1	2	3	COMPOSITION AND LIVE ROOM OUTPUTS				6	7	8	9	10	11	COMPOSITION AND LIVE ROOM OUTPUTS				16	1	2	3	COMPOSITION AND LIVE ROOM INPUTS				8	G
	ANALOG	1	2	3	4	5	6	7	8	9	10	11	12	13	14	15	16	17	18	19	20	21	22	23	24	ANALOG	
H	17	18	19	COMPOSITION AND LIVE ROOM OUTPUTS				22	23	24	25	26	27	COMPOSITION AND LIVE ROOM OUTPUTS				32	9	10	11	COMPOSITION AND LIVE ROOM INPUTS				16	H
	ANALOG	17	18	19	20	21	22	23	24	25	26	27	28	29	30	31	32	9	10	11	12	13	14	15	16	ANALOG	

N	1	2	3	STUDIO L OUTPUTS				6	7	8	9	10	11	STUDIO L OUTPUTS				16	1	2	3	STUDIO L INPUTS				8	N
	ANALOG	1	2	3	4	5	6	7	8	9	10	11	12	13	14	15	16	17	18	19	20	21	22	23	24	ANALOG	
P	17	18	19	STUDIO L OUTPUTS				22	23	24	25	26	27	STUDIO L OUTPUTS				32	9	10	11	STUDIO L INPUTS				16	P
	ANALOG	17	18	19	20	21	22	23	24	25	26	27	28	29	30	31	32	9	10	11	12	13	14	15	16	ANALOG	

Q	1	2	3	STUDIO K OUTPUTS				6	7	8	9	10	11	STUDIO K OUTPUTS				16	1	2	3	STUDIO K INPUTS				8	Q
	ANALOG	1	2	3	4	5	6	7	8	9	10	11	12	13	14	15	16	17	18	19	20	21	22	23	24	ANALOG	
R	17	18	19	STUDIO K OUTPUTS				22	23	24	25	26	27	STUDIO K OUTPUTS				32	9	10	11	STUDIO K INPUTS				16	R
	ANALOG	17	18	19	20	21	22	23	24	25	26	27	28	29	30	31	32	9	10	11	12	13	14	15	16	ANALOG	

S	1	2	3	STUDIO R OUTPUTS				6	7	8	1	2	3	STUDIO R INPUTS				4	1	2	3	STUDIO P ROOM OUTPUTS				8	1	2	3	STUDIO P INPUTS				4	S
	ANALOG	1	2	3	4	5	6	7	8	9	10	11	12	13	14	15	16	17	18	19	20	21	22	23	24	ANALOG									
T	1	2	3	STUDIO O OUTPUTS				6	7	8	1	2	3	STUDIO O INPUTS				4	1	2	3	STUDIO N OUTPUTS				8	1	2	3	STUDIO N INPUTS				4	T
	ANALOG	1	2	3	4	5	6	7	8	9	10	11	12	13	14	15	16	17	18	19	20	21	22	23	24	ANALOG									

U	1	2	3	STUDIO W OUTPUTS				6	7	8	1	2	3	STUDIO W INPUTS				4	1	2	3	TECHNICAL OFFICE OUTPUTS				8	1	2	3	TECHNICAL OFFICE OUTPUTS				4	U
	ANALOG	1	2	3	4	5	6	7	8	9	10	11	12	13	14	15	16	17	18	19	20	21	22	23	24	ANALOG									
V	1	2	3	GROUND FLOOR ISOLATION BOOTH OUTPUTS				6	7	8	1	2	3	GROUND FLOOR ISOLATION BOOTH INPUTS				4	1	2	3					8	1	2	3					4	V
	ANALOG	1	2	3	4	5	6	7	8	9	10	11	12	13	14	15	16	17	18	19	20	21	22	23	24	ANALOG									

L	1	2	3	HIGH LEVEL WALLBOX OUTPUTS				6	7	8	9	10	11	HIGH LEVEL WALLBOX OUTPUTS				16	17	18	19	20	21	22	23	24	L			
	ANALOG	1	2	3	4	5	6	7	8	9	10	11	12	13	14	15	16	17	18	19	20	21	22	23	24	ANALOG				
M																		LEFT	RIGHT	LEFT	RIGHT									M
																		SONIFEX PHONES 1 IN	SONIFEX PHONES 1 IN	SONIFEX PHONES 2 IN	SONIFEX PHONES 2 IN									

Control 1 - Audio

A	CENTRAL PATCHBAY OUTPUTS																								A								
	1	2	3	4	5	6	7	8	9	10	11	12	13	14	15	16	17	18	19	20	21	22	23	24		ANALOG							
B	SSL MIC INPUT																								B								
	1 (N)	2 (N)	3 (N)	4 (N)	5 (N)	6 (N)	7 (N)	8 (N)	9 (N)	10 (N)	11 (N)	12 (N)	13 (N)	14 (N)	15 (N)	16 (N)	17 (N)	18 (N)	19 (N)	20 (N)	21 (N)	22 (N)	23 (N)	24 (N)		ANALOG							
C	DAW OUTPUT								DAW OUTPUT								DAW OUTPUT								C								
	1	2	3	4	5	6	7	8	9	10	11	12	13	14	15	16	17	18	19	20	21	22	23	24		ANALOG							
D	SSL LINE INPUT																								D								
	1 (N)	2 (N)	3 (N)	4 (N)	5 (N)	6 (N)	7 (N)	8 (N)	9 (N)	10 (N)	11 (N)	12 (N)	13 (N)	14 (N)	15 (N)	16 (N)	17 (N)	18 (N)	19 (N)	20 (N)	21 (N)	22 (N)	23 (N)	24 (N)		ANALOG							
E	INSERT SENDS								INSERT SENDS								INSERT SENDS								E								
	1	2	3	4	5	6	7	8	9	10	11	12	13	14	15	16	17	18	19	20	21	22	23	24		ANALOG							
F	INSERT RETURNS																								F								
	1 (N)	2 (N)	3 (N)	4 (N)	5 (N)	6 (N)	7 (N)	8 (N)	9 (N)	10 (N)	11 (N)	12 (N)	13 (N)	14 (N)	15 (N)	16 (N)	17 (N)	18 (N)	19 (N)	20 (N)	21 (N)	22 (N)	23 (N)	24 (N)		ANALOG							
G	SSL DIRECT OUTPUT								SSL DIRECT OUTPUT								SSL DIRECT OUTPUT								G								
	1	2	3	4	5	6	7	8	9	10	11	12	13	14	15	16	17	18	19	20	21	22	23	24		ANALOG							
H	DAW INPUT																								H								
	1 (N)	2 (N)	3 (N)	4 (N)	5 (N)	6 (N)	7 (N)	8 (N)	9 (N)	10 (N)	11 (N)	12 (N)	13 (N)	14 (N)	15 (N)	16 (N)	17 (N)	18 (N)	19 (N)	20 (N)	21 (N)	22 (N)	23 (N)	24 (N)		ANALOG							
I	REC INSERT		MIX INSERT		REC OUTPUT		6 TRK PLAYBACK 1				DAT		SAMSUNG DVD		MD		SPARE		SONY DVDR OUTPUT		SONY DVDR INPUT		I										
	L	R	L	R	L	R	L	R	L	R	L	R	L	R	L	R	L	R	L	R	L	R		ANALOG									
J	REC RETURN		MIX RETURN		MIX OUTPUT		EXT A 6 TRK INPUT				EXT B INPUT				MD INPUT		DAT INPUT		J														
	L (N)	R (N)	L (N)	R (N)	L	R	L (N)	R (N)	C (N)	LFE (N)	LS (N)	RS (N)	1L (N)	1R (N)	2L (N)	2R (N)	3L (N)	3R (N)		4L (N)	4R (N)	L	R	ANALOG									
K	CUE A		CUE B		FX SENDS				MOOG DELAY OUTPUT		VERMONA DSR-3 OUTPUT		PCM-70 OUTPUT		RUPERT NEVE 542 OUTPUT		LSN		TB		GENELEC SUB OUTPUT				K								
	L	R	L	R	1	2	3	4	1	2	L	R	L	R	1	2	OP	OP	L	R	C	LS	RS	ANALOG									
L	MOOG DELAY INPUT		VERMONA DSR-3 INPUT		PCM-70 IN		SPARE		RUPERT NEVE 542 INPUT				STEREO RETURN				IP (N)		LSN IP		GENELEC ARRAY				L								
	1	2	L	R	1 (N)	(N)	1 (N)	2 (N)	1L (N)	1R (N)	2L (N)	2R (N)	3L (N)	3R (N)	4L (N)	4R (N)	IP (N)	OP	L (N)	R (N)	C (N)	LS (N)	RS	ANALOG									
M	MAIN LS A						MINI A		MAIN LS B						MINI B		FB A		FB B		SPARE				M								
	L	R	C	LFE	LS	RS	L	R	L	R	C	LFE	LS	RS	L	R	LEFT	RIGHT	LEFT	RIGHT	1	2	3	4		ANALOG							
N	GENELEC SUB INPUT				NEAR FIELD				CENTRAL PATCHBAY INPUTS								CENTRAL PATCHBAY INPUTS								N								
	L (N)	R (N)	C (N)	LFE (N)	LS (N)	RS (N)	1 (N)	2 (N)	1 (N)	2 (N)	3 (N)	4 (N)	5 (N)	6 (N)	7 (N)	8 (N)	9 (N)	10 (N)	11 (N)	12 (N)	13 (N)	14 (N)	15 (N)	16 (N)		ANALOG							
O	CENTRAL PATCHBAY OUTPUTS								DAW OUTPUT								LIQUID 1 OUT		LIQUID 2 OUT		PARALLEL				O								
	25	26	27	28	29	30	31	32	25	26	27	28	29	30	31	32	LINE	LINE	A	A	A	A	ANALOG										
P	DAW INPUT								CUE/FX BUS INJECTION								MIC (N)		LINE (N)		MIC (N)		LINE (N)		PARALLEL				P				
	25 (N)	26 (N)	27 (N)	28 (N)	29 (N)	30 (N)	31 (N)	32 (N)	1 (N)	2 (N)	3 (N)	4 (N)	5 (N)	6 (N)	7 (N)	8 (N)	LIQUID 1 IN	LIQUID 2 IN	B	B	B	B	ANALOG										
Q	XFILTER OUTPUT		LEVIATHAN OUTPUT		ACTION OUTPUT		TUBECORE OUT																		Q								
	L	R	1	2	1	2	1	2	ANALOG																								
R	XFILTER INPUT		LEVIATHAN INPUT		ACTION INPUT		TUBECORE IN										ST CUE AL		ST CUE AR		ST CUE BL		ST CUE BR		FX 1		FX 2		FX 3		FX 4		R
	L	R	1	2	1	2	1	2	ANALOG																								

Control 2 - Audio

A	CENTRAL PATCHBAY OUTPUTS								CENTRAL PATCHBAY OUTPUTS								CENTRAL PATCHBAY OUTPUTS								A													
	1	2	3	4	5	6	7	8	9	10	11	12	13	14	15	16	17	18	19	20	21	22	23	24														
B	DESK MIC INPUTS								DESK MIC INPUTS								DESK MIC INPUTS								B													
ANALOG	1	2	3	4	5	6	7	8	9	10	11	12	13	14	15	16	17	18	19	20	21	22	23	24														
C	CENTRAL PATCHBAY OUTPUTS								MX40 PUNCHGATE				DS201 DUAL GATE -1				DS201 DUAL GATE -2				GRAPHIC EQ OUT				C													
D	25	26	27	28	29	30	31	32	OUT 1	OUT 2	OUT 3	OUT 4	OUT 1	KEY 1	OUT 2	OUT 1	KEY 1	OUT 2	OUT 1	KEY 1	OUT 2	L	R	L		R												
ANALOG	1	2	3	4	5	6	7	8	9	10	11	12	13	14	15	16	17	18	19	20	21	22	23	24														
E																									E													
F	DESK LINE INPUTS																								F													
ANALOG	1	2	3	4	5	6	7	8	9	10	11	12	13	14	15	16	17	18	19	20	21	22	23	24														
G	DESK GROUP SENDS								DESK AUX OUTPUTS				DL 241 COMPRESSOR				DL 221 COMPRESSOR				PARALLEL				G													
H	1	2	3	4	5	6	7	8	CUE A	CUE B	OUT L	OUT R	OUT L	SEND L	OUT R	SEND R	A	A	PARALLEL	A	A	B	B	PARALLEL		B	B											
ANALOG	1	2	3	4	5	6	7	8	9	10	11	12	13	14	15	16	17	18	19	20	21	22	23	24														
J	DESK TAPE/DAW SENDS								DESK TAPE/DAW SENDS								DESK TAPE/DAW SENDS								J													
K	1	2	3	4	5	6	7	8	9	10	11	12	13	14	15	16	17	18	19	20	21	22	23	24														
ANALOG	1	2	3	4	5	6	7	8	9	10	11	12	13	14	15	16	17	18	19	20	21	22	23	24														
L	DESK LINE SENDS								DESK LINE SENDS								DESK LINE SENDS								L													
M	1	2	3	4	5	6	7	8	9	10	11	12	13	14	15	16	17	18	19	20	21	22	23	24														
ANALOG	1	2	3	4	5	6	7	8	9	10	11	12	13	14	15	16	17	18	19	20	21	22	23	24														
N	DAW OUTPUTS								DAW OUTPUTS								DAW OUTPUTS								N													
P	1	2	3	4	5	6	7	8	9	10	11	12	13	14	15	16	17	18	19	20	21	22	23	24														
ANALOG	1	2	3	4	5	6	7	8	9	10	11	12	13	14	15	16	17	18	19	20	21	22	23	24														
Q	DESK CHANNEL DIRECT OUTPUTS								DESK CHANNEL DIRECT OUTPUTS								DESK CHANNEL DIRECT OUTPUTS								Q													
R	1	2	3	4	5	6	7	8	9	10	11	12	13	14	15	16	17	18	19	20	21	22	23	24														
ANALOG	1	2	3	4	5	6	7	8	9	10	11	12	13	14	15	16	17	18	19	20	21	22	23	24														
S	DESK VCA OUTPUTS								DESK SUB GROUP BUS OUTPUTS								DESK FOLD BACK 1 OUT				DESK FOLD BACK 2 OUT				DESK STUDIO LS				DESK MIX OUT 1				S					
T	25	26	27	28	29	30	31	32	1	2	3	4	5	6	7	8	LEFT	RIGHT	LEFT	RIGHT	L	R	L	R	L	R	L	R	L	R	L	R						
ANALOG	1	2	3	4	5	6	7	8	9	10	11	12	13	14	15	16	17	18	19	20	21	22	23	24														
U	DESK AUX OUTPUTS								DESK MAIN SEND				DESK MIX OUTPUT 2				DVR A1000 OUT				MINIDISC OUT				DESK MIX OUTPUT 3				BALANCING UNIT OUT				U					
V	L(N)	R(N)	L(N)	R(N)	L(N)	R(N)	L(N)	R(N)	L	R	L	R	L	R	L	R	L	R	L	R	L	R	L	R	L	R	L	R	L	R	L	R						
ANALOG	1	2	3	4	5	6	7	8	9	10	11	12	13	14	15	16	17	18	19	20	21	22	23	24														
W	PCM80 OUT				DSR-3 OUT				FX3 OUT				FX3 OUT				DAW OUTPUT								DESK ALT LOUSPEAKER 2				DESK ALT LOUSPEAKER 3				W					
X	L	R	L	R	L	R	L	R	L	R	L	R	L	R	25	26	27	28	29	30	31	32	L	R	L	R	L	R	L	R	L	R		L	R	L	R	L
ANALOG	1	2	3	4	5	6	7	8	9	10	11	12	13	14	15	16	17	18	19	20	21	22	23	24														

Control 3 - Audio

A	CENTRAL PATCHBAY OUTPUTS																CENTRAL PATCHBAY OUTPUTS								CENTRAL PATCHBAY OUTPUTS								A
ANALOG	1	2	3	4	5	6	7	8	9	10	11	12	13	14	15	16	17	18	19	20	21	22	23	24	ANALOG								
B	CENTRAL PATCHBAY INPUTS								CENTRAL PATCHBAY INPUTS																B								

C	CR3 ISOLATION BOOTH OUTPUTS																								C
ANALOG	1	2	3	4	5	6	7	8	9	10	11	12	13	14	15	16	17	18	19	20	21	22	23	24	ANALOG
D	1 (N)		2 (N)		3 (N)		4 (N)		5 (N)		6 (N)		7 (N)		8 (N)										D

E	PRE LINE OUTPUTS																								E
ANALOG	1	2	3	4	5	6	7	8	9	10	11	12	13	14	15	16	17	18	19	20	21	22	23	24	ANALOG
F	1 (N)		2 (N)		3 (N)		4 (N)		5 (N)		6 (N)		7 (N)		8 (N)										F

G	CENTRAL PATCHBAY OUTPUTS								DAW OUTPUTS																PARALLEL				G								
ANALOG	25	26	27	28	29	30	31	32	1	2	3	4	5	6	7	8	9	10	11	12	13	14	15	16	17	18	19	20	21	22	23	24	ANALOG				
H									1 (N)		2 (N)		3 (N)		4 (N)		5 (N)		6 (N)		7 (N)		8 (N)										PARALLEL				H

N	KURZWEIL OUTPUTS								SPL MONITORS OUTPUTS																N								
ANALOG	1	2	3	4	5	6	7	8	9	10	11	12	13	14	15	16	17	18	19	20	21	22	23	24	ANALOG								
P									1 (N)		2 (N)		3 (N)		4 (N)		5 (N)		6 (N)		7 (N)		8 (N)										P

Q	DVRA1000 OUT L R		MINI DISC OUT L R		KURZWEIL OUTPUTS MIX L MIX R								OBERHEIM 1000 OUT										Q						
ANALOG	1	2	3	4	5	6	7	8	9	10	11	12	13	14	15	16	17	18	19	20	21	22	23	24	ANALOG				
R	DVRA1000 IN		MINI DISC IN				L/M R								WALL AUDIO TIE										CR3 ISOLATION BOOTH INPUTS				R

Control 4 - Audio

A	STUDIO L OUTPUTS																								A
ANALOG	1	2	3	4	5	6	7	8	9	10	11	12	13	14	15	16	17	18	19	20	21	22	23	24	ANALOG
B	PRE MIC INPUTS																STUDIO L INPUTS								B
	1 (N)	2 (N)	3 (N)	4 (N)	5 (N)	6 (N)	7 (N)	8 (N)									1	2	3	4	5	6	7	8	

C	PRE LINE OUTPUTS								DAW OUTPUTS																C							
ANALOG	1	2	3	4	5	6	7	8	9	10	11	12	13	14	15	16	17	18	19	20	21	22	23	24	ANALOG							
D	DAW INPUTS								SPEAKER INPUTS										PARALLEL				D									
	1 (N)	2 (N)	3 (N)	4 (N)	5 (N)	6 (N)	7 (N)	8 (N)	L (N)	R (N)															A	A	A	A	B	B	B	B

E																									E
ANALOG																									ANALOG
F																									F

G																									G
ANALOG																									ANALOG
H																									H

N																									N
ANALOG																									ANALOG
P																									P

Q																									Q
ANALOG																									ANALOG
R																									R

Composition and Live Room Trolley

A	CENTRAL PATCHBAY OUTPUTS								CENTRAL PATCHBAY OUTPUTS								CENTRAL PATCHBAY OUTPUTS								A
	1	2	3	4	5	6	7	8	9	10	11	12	13	14	15	16	17	18	19	20	21	22	23	24	
B	DESK MIC INPUTS								DESK MIC INPUTS								DESK MIC INPUTS								B
C																	RME FIREFACE 802 OUTPUTS								C
ANALOG	1	2	3	4	5	6	7	8	9	10	11	12	13	14	15	16	17	18	19	20	21	22	23	24	ANALOG
D	DESK LINE INPUTS								DESK LINE INPUTS								DESK LINE INPUTS								D
E	DESK SENDS								DESK SENDS								DESK SENDS								E
ANALOG	1	2	3	4	5	6	7	8	9	10	11	12	13	14	15	16	17	18	19	20	21	22	23	24	ANALOG
F	DESK INSERT / RETURNS								DESK INSERT / RETURNS								DESK INSERT / RETURNS								F
G	DESK DIRECT OUTPUTS / TAPE SEND								DESK DIRECT OUTPUTS / TAPE SEND								DESK DIRECT OUTPUTS / TAPE SEND								G
ANALOG	1	2	3	4	5	6	7	8	9	10	11	12	13	14	15	16	17	18	19	20	21	22	23	24	ANALOG
H	DESK MIX B / TAPE RETURN								DESK MIX B / TAPE RETURN								DESK MIX B / TAPE RETURN								H
J	DESK GROUP SENDS								DESK GROUP OUTPUTS																J
ANALOG	1	2	3	4	5	6	7	8	9	10	11	12	13	14	15	16	17	18	19	20	21	22	23	24	ANALOG
K	DESK GROUP RETURNS								CENTRAL PATCHBAY INPUTS								CENTRAL PATCHBAY INPUTS								K
L	DESK 2TRKA INPUT		DESK FX INPUTS				DESK MIX SEND		DESK MIX OUTPUT		DESK STD A LS		DESK CRM LS		DESK AUX OUTPUTS								L		
ANALOG	L	R	1L	1R	2L	2R	L	R	L	R	L	R	L	R	1	2	3	4	5	6	7L	7R	8L	8R	ANALOG
M	DESK 2TRKB INPUT		DESK FX INPUTS				DESK MIX RETURN		DESK MIX B		DESK STD PHONES B		DESK ALT LS		AUX FEEDS - BACK OF TROLLEY (HEADPHONES)								M		
ANALOG	L	R	3L	3R	4L	4R	L(N)	R(N)	L	R	L	R	L	R	1(N)	2(N)	3(N)	4(N)	5(N)	6(N)	7L(N)	7R(N)	8L(N)	8R(N)	ANALOG
N													CENTRAL PATCHBAY OUTPUTS								PARALLEL				N
ANALOG	1	2	3	4	5	6	7	8	9	10	11	12	13	14	15	16	17	18	19	20	21	22	23	24	ANALOG
P	SPEAKER SOCKETS - BACK OF TROLLEY												CENTRAL PATCHBAY INPUTS								PARALLEL				P
ANALOG	1	2	3	4	5	6	7	8	9	10	11	12	13	14	15	16	17	18	19	20	21	22	23	24	ANALOG
Q	RME ADI 8 DS CONVERTER LINE OUTPUTS																								Q
ANALOG	1	2	3	4	5	6	7	8	9	10	11	12	13	14	15	16	17	18	19	20	21	22	23	24	ANALOG
R	RME ADI 8 DS CONVERTER LINE INPUTS								RME FIREFACE 802 LINE INPUTS																R
ANALOG	1	2	3	4	5	6	7	8	9	10	11	12	13	14	15	16	17	18	19	20	21	22	23	24	ANALOG

